

Understanding South African Financial Markets

Chapter 1: Fundamentals of the financial system



© VAN SCHAIK PUBLISHERS

Study outcomes

When you have studied this chapter you should be able to

- define and describe the elements that make up the financial system
- elucidate the functions of the financial system
- discuss the significance of financial system stability in a domestic and international context
- outline the recent international financial crisis and its implications for the future.



© VAN SCHAIK PUBLISHERS

Introduction

Overview

- Defining the financial system
- Six elements of the financial system
- Functions of the financial system
- Domestic and international financial system stability
- The international financial crisis and the future

© VAN SCHAIK PUBLISHERS

Defining the financial system

Figure 1.1 Financial system (simplified) (Textbook page 4)

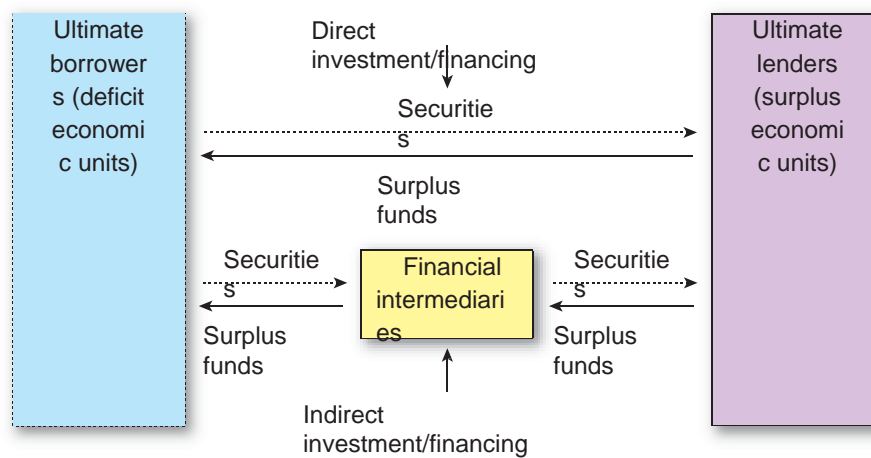

© VAN SCHAIK PUBLISHERS

Defining the financial system

Figure 1.2 Financial markets and broker-dealers in financial system (Textbook page 5)

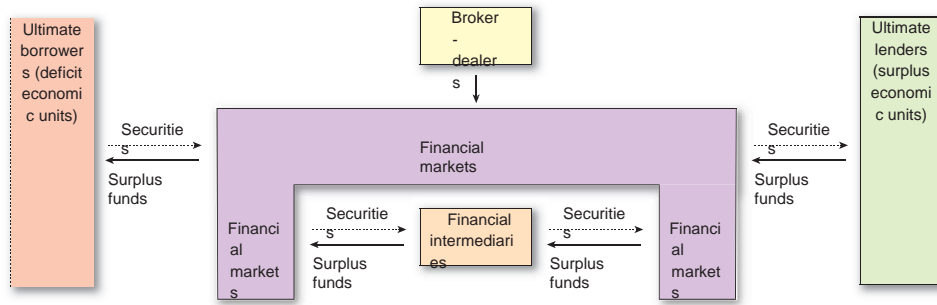

© VAN SCHAIK PUBLISHERS

Defining the financial system

Figure 1.3 (Most) elements of the financial system (Textbook page 7)

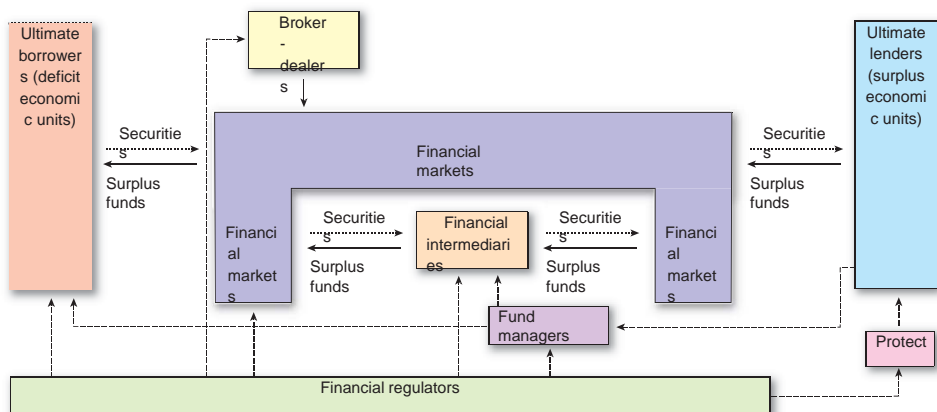

© VAN SCHAIK PUBLISHERS

Six elements of the financial system

1. *Lenders and borrowers*
2. *Financial intermediaries*
3. *Financial instruments*
4. *Creation of money*
5. *Financial markets*
6. *Price discovery*



© VAN SCHAIK PUBLISHERS

Six elements of the financial system

Element 1: lenders and borrowers

- *Household sector*
- *Corporate sector*
- *Government sector*
- *Foreign sector*



© VAN SCHAIK PUBLISHERS

Six elements of the financial system

Element 1: lenders and borrowers

Figure 1.4 Ultimate lenders and borrowers (Textbook page 8)

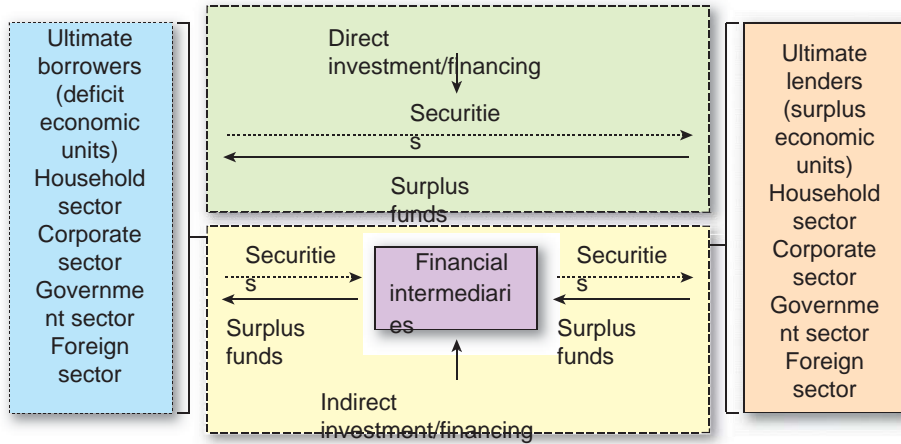

© VAN SCHAIK PUBLISHERS

Six elements of the financial system

Element 2: financial intermediaries

Table 1.1 Financial intermediaries (Textbook 8)

Figure 1.5 Financial intermediaries (Textbook page 9)

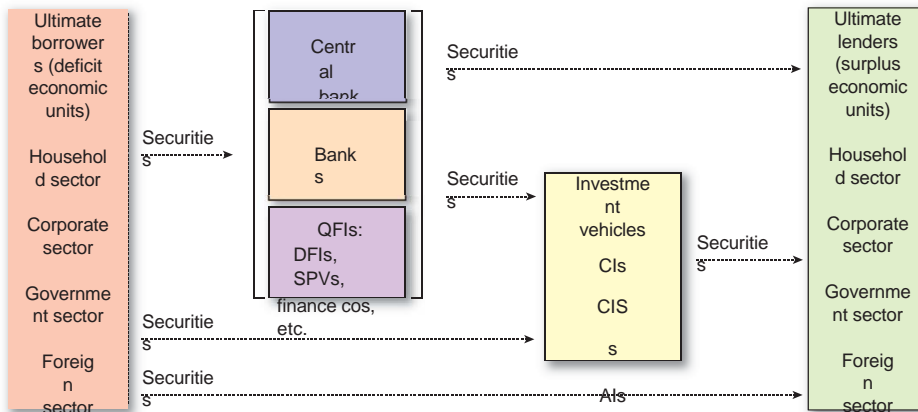

© VAN SCHAIK PUBLISHERS

Element 3: financial instruments

Figure 1.6 Financial intermediaries and instruments/securities (Textbook page 11)

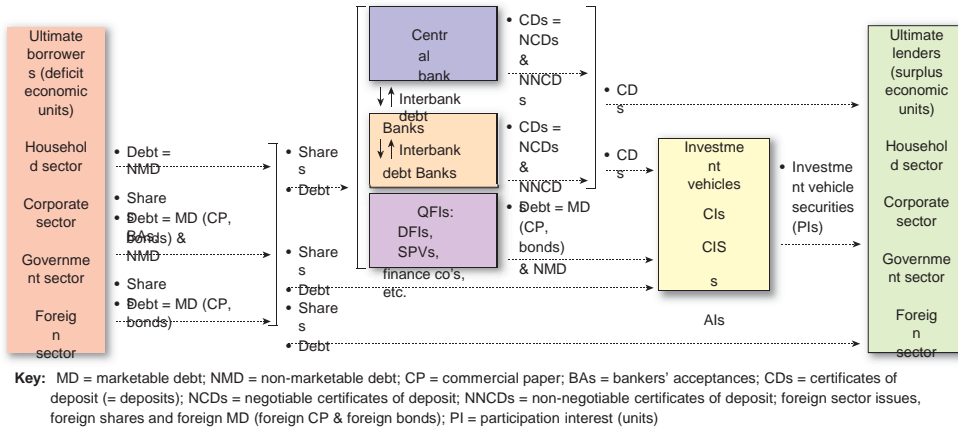
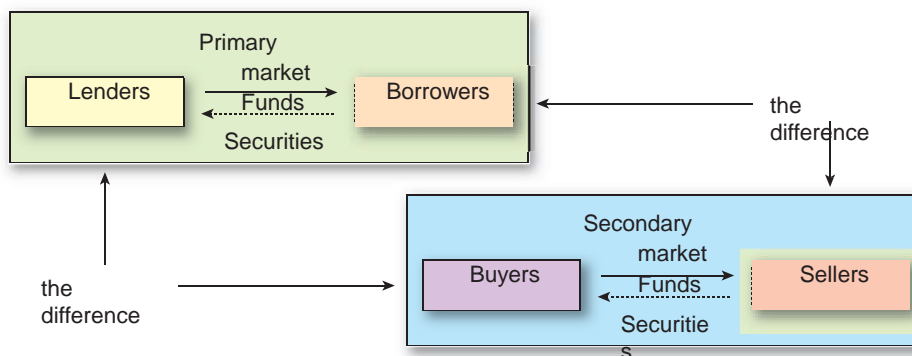

Table 1.2 Financial instruments/securities (Textbook page 13)

Element 4: financial markets

- Primary and secondary markets

Figure 1.7 Primary and secondary markets (Textbook page 14)



Six elements of the financial system

Element 4: financial markets

- Over-the-counter and exchange-driven markets
- Debt market

Figure 1.8 Money market (Textbook page 16)

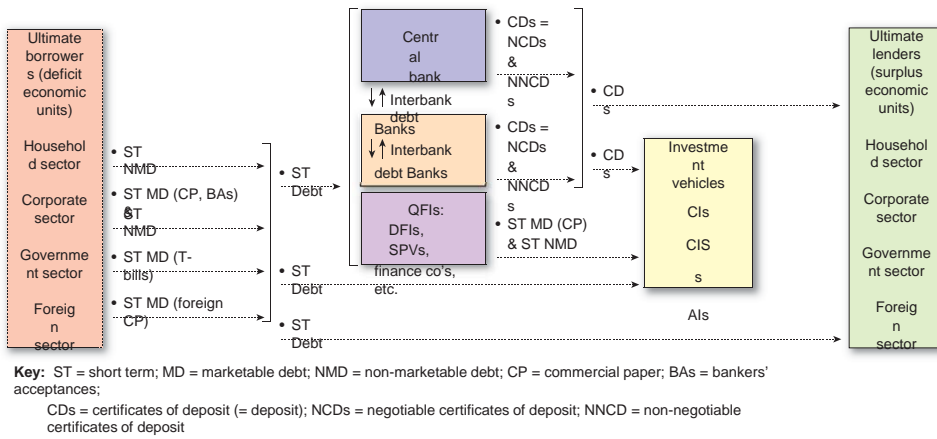

© VAN SCHAIK PUBLISHERS

Six elements of the financial system

Element 4: financial markets

Figure 1.9 Bond market (Textbook page 18)

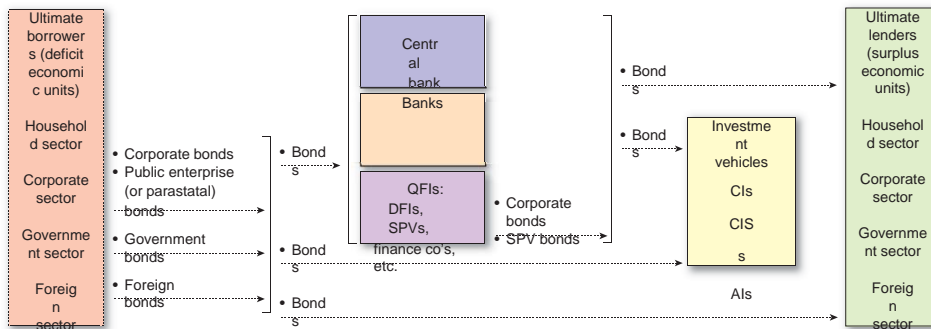

© VAN SCHAIK PUBLISHERS

Six elements of the financial system

Element 4: financial markets

• Share market

Figure 1.10 Share market (Textbook page 19)

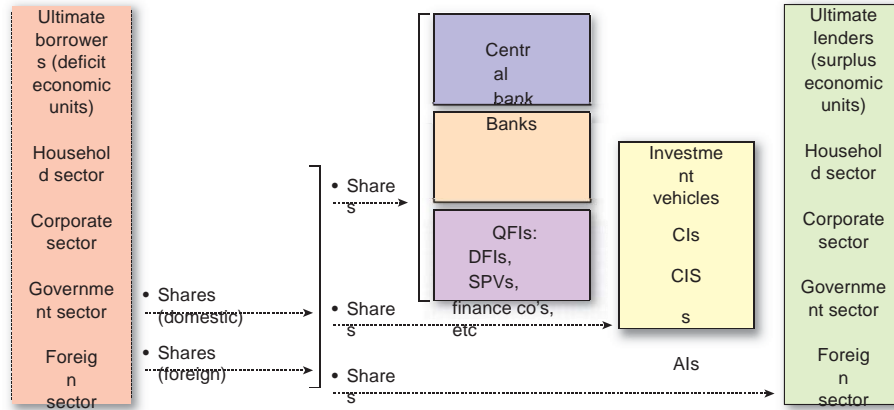

© VAN SCHAIK PUBLISHERS

Six elements of the financial system

Element 4: financial markets

• Foreign exchange market

Figure 1.11 Financial markets (Textbook page 20)

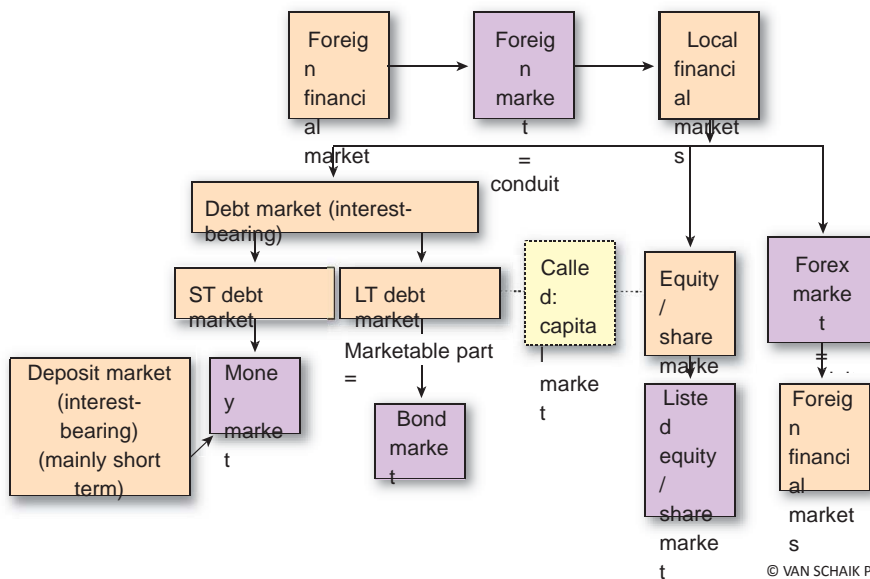

© VAN SCHAIK PUBLISHERS

Six elements of the financial system

Element 4: financial markets

• Spot and derivatives markets

Figure 1.12 Spot and forward settlement (derivatives markets) (Textbook page 21)

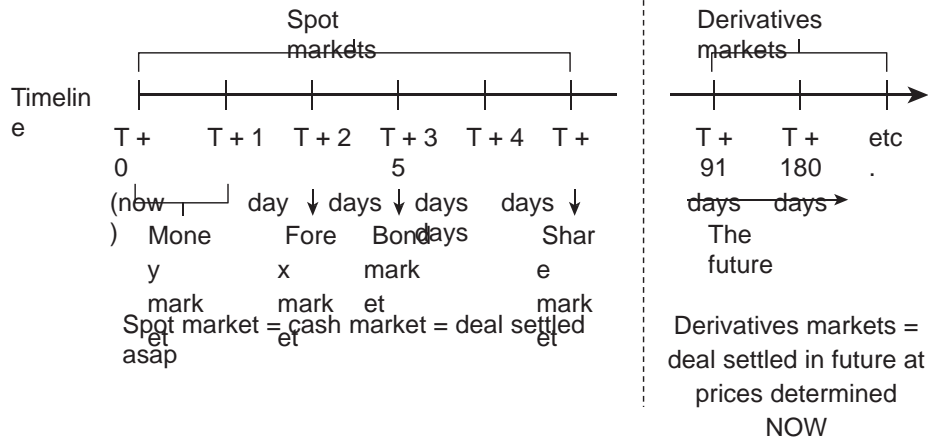

© VAN SCHAIK PUBLISHERS

Six elements of the financial system

Element 4: financial markets

Figure 1.13 Derivatives instruments/markets (Textbook page 21)

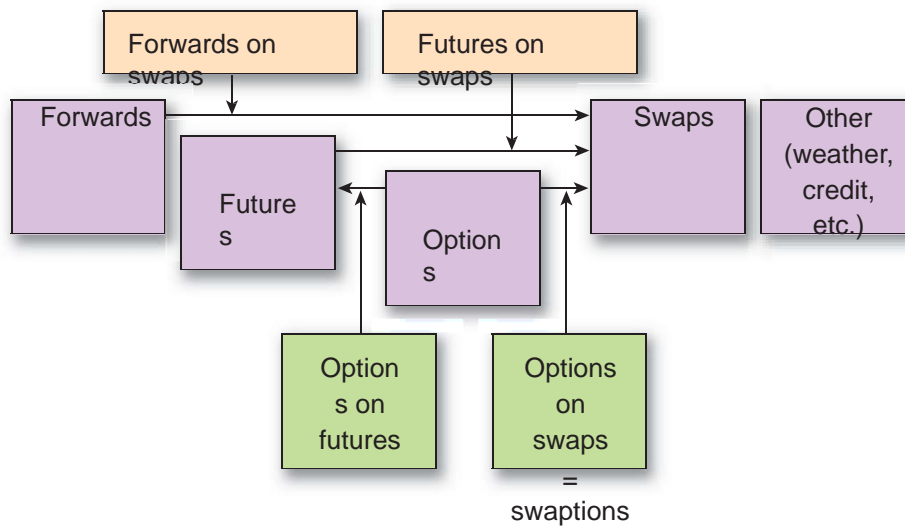

© VAN SCHAIK PUBLISHERS

Element 5: money creation

Figure 1.14 Money creation (Textbook page 23)

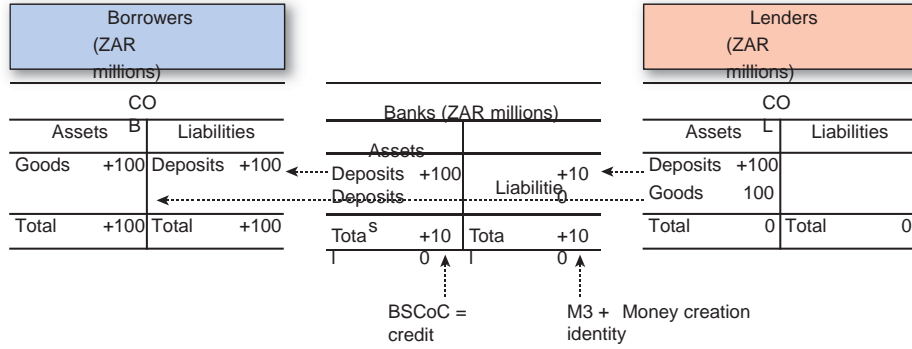

Element 5: money creation

Figure 1.15 Repo rate and prime rate (Textbook page 24)

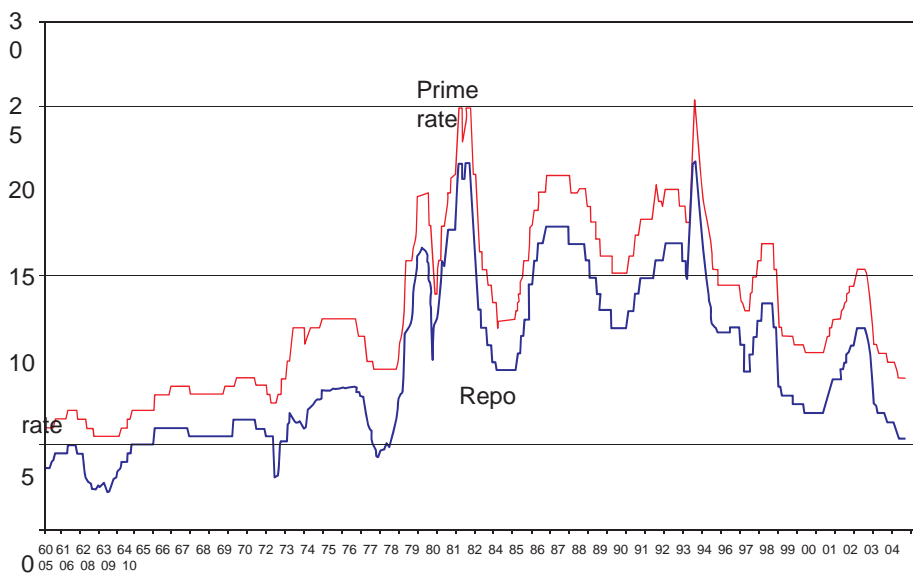

Element 6: price discovery

Figure 1.16 Short-term banking rates and yield curve for government securities (Textbook page 25)

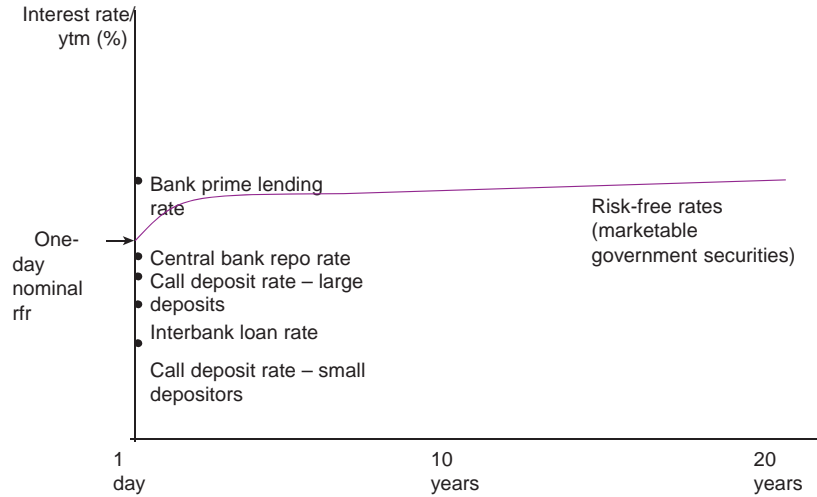

© VAN SCHAIAK PUBLISHERS

Element 6: price discovery

Figure 1.17 Three- and 10-year bond rates (Textbook page 26)

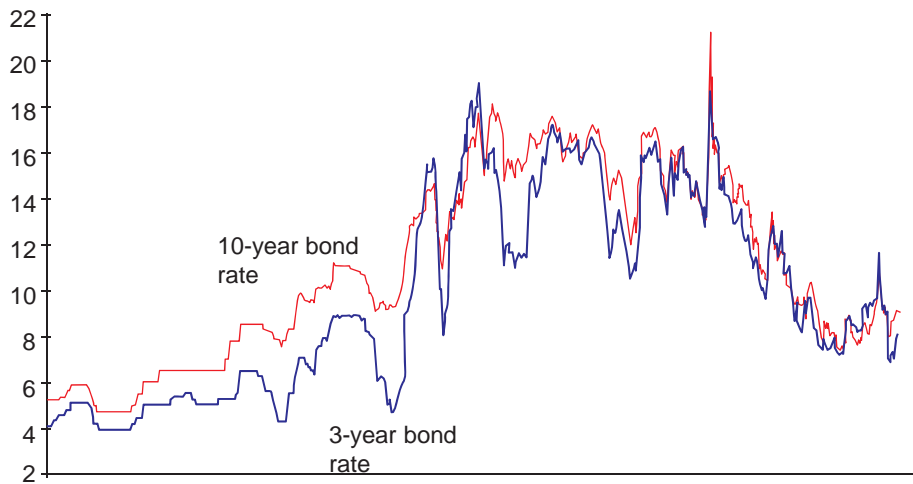

© VAN SCHAIAK PUBLISHERS



Element 7: allied participants in the financial system

- *Principal participants*
- *Non-principal participants*



Functions of the financial system

Introduction

Channelling of savings into investments

Pooling of savings

Efficient allocation of funds

- Transferring of funds through time and across borders



Money creation

An efficient payment system

Enhanced liquidity and economies of scale

Reduction of risk

Price discovery/information



**Domestic and international
financial system stability**

The international financial crisis and the future



© VAN SCHAİK PUBLISHERS